

TopGear

Gear Pumps



TopGear –

When reliability is the priority

Gear pumps are used in all types of manufacturing industries for the transportation of both thin and thick liquids, from chocolate to diesel fuel. Our gear pumps have a sturdy design, offering high reliability as well as long life.

We make gear pumps that our customers can rely on.

The moment you buy a gear pump from Johnson Pump, you will join thousands of industrial customers who rely on our pump technology.

Their main interest is not the pump itself, but smooth, high-quality, uninterrupted production – at a lower total cost.

Johnson Pump has more than 50 years of experience in developing and manufacturing gear pumps and is one of the leading suppliers in the market.

The wide Johnson Pump TopGear programme is divided into three ranges :

the L-range : Low viscosity - high efficiency

the G-range : General purpose

the H-range : High demanding applications



Typical characteristics

- Robust and reliable operation
- High and low viscous products
- Smooth flow
- Simple design - only two moving parts
- Easy maintenance
- Reduced down time for service
- Wide range of materials
- High efficiency
- Conforms to API 676

TopGear –

Knowledge results in the perfect solution

Technical know-how and customer knowledge have been the driving forces for Johnson Pump when designing the programme of gear pumps. TopGear pumps are used in various industries and environments, which have thousands of liquids that need to be pumped.

TopGear offers a combination of strong design with small or large clearances, unique gear tooth profile and options such as electrical heating and built-on safety relief valves.

Sometimes the fluids are explosive, sometimes poisonous. They can be free-flowing or extremely viscous. Johnson Pump has the experience and knowledge to meet the demands these different characteristics place on the pumps.

Together with our customers we select the right material and choose the right seal options to help you reach the optimal lifetime for the pump in various applications.

- **Petrochemicals**
Pure or filled bitumen, pitch, diesel oil, crude oil, lube oil
- **Chemicals**
Sodium silicate, acids, plastics, mixed chemicals, isocyanates
- **Paint and Ink**
- **Resins and Adhesives**
- **Pulp & Paper**
Acid, soap, lye, black liquor, kaolin, lime, latex, sludge
- **Food**
Chocolate, cacao butter, fillers, sugar, vegetable fats and oils, molasses, animal food



Features and Benefits

Improved priming, low NPSHr

- Ports above centerline
- Maximised ports

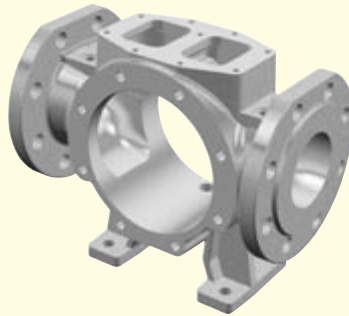

Flange connections options

- EN
- ANSI

Improved design for low and high viscous media

- Optimised teeth profile
- Smooth flow

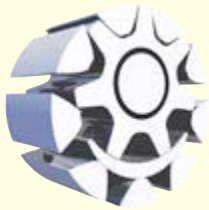

H-range/G-range

Optimised efficiency

- Axial rotor locking
- Adjustable clearances
- Hydraulic design

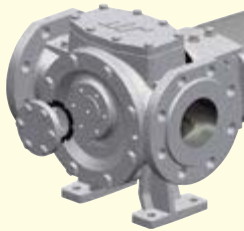

Eliminated leakage during thermal expansion

- Pin cover
- Safety sealed

Less downtime

- Front and back pull-out

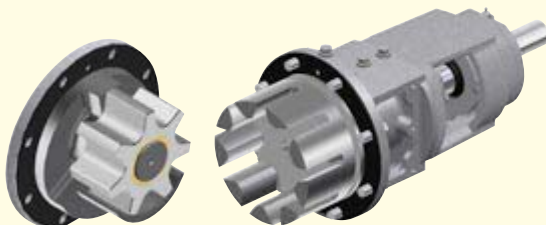

Prolonged service life

- Double ball bearing design
- Adjustable axial clearance
- Allows V-belt drive
- Accepts higher axial forces

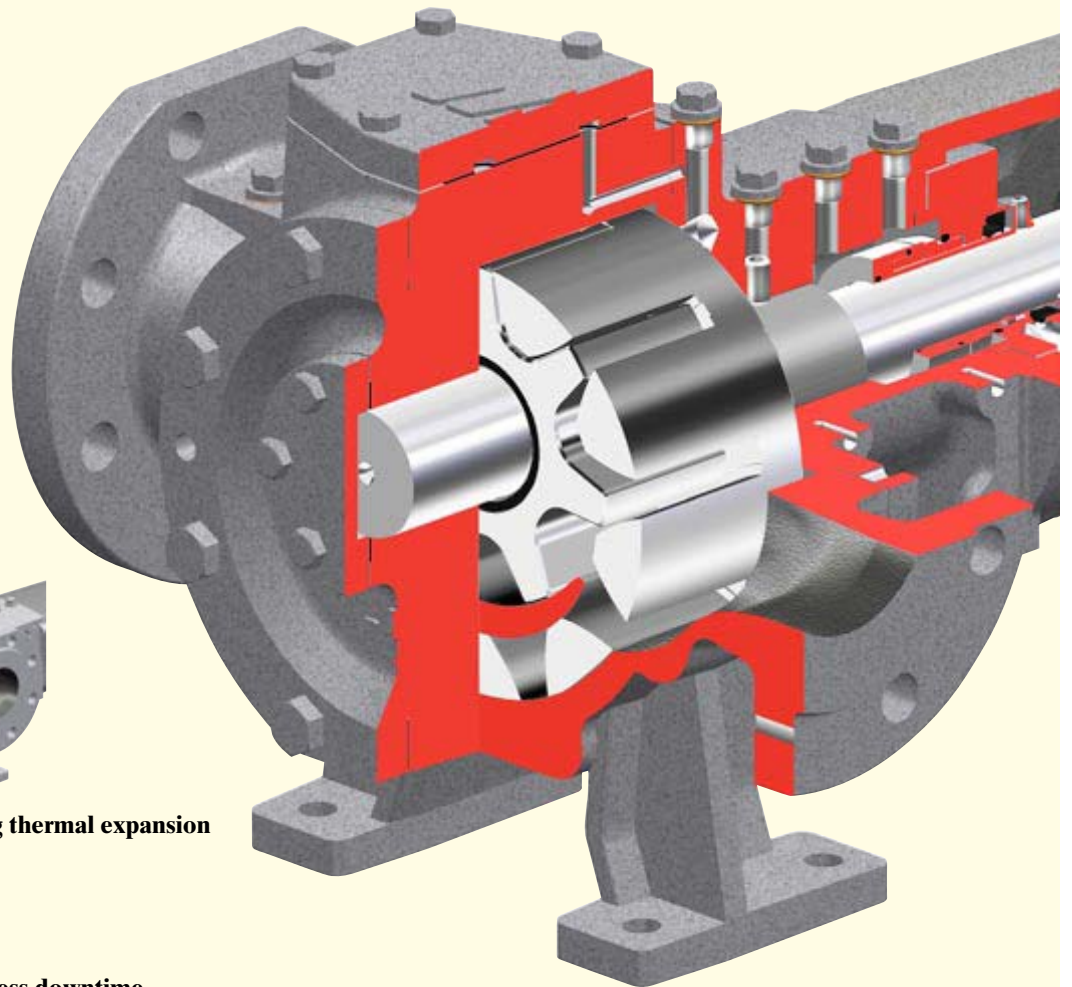

Several material options

- Shaft seal materials
- Bearing materials
- Hydraulic parts

High volumetric efficiency

- Small radial and axial clearances
 - reduced slip
- Optimised rotor/gear shape

Long service life

- Large bearing diameters
- Rotors machined in one piece from steel bar
- Hardened interior parts

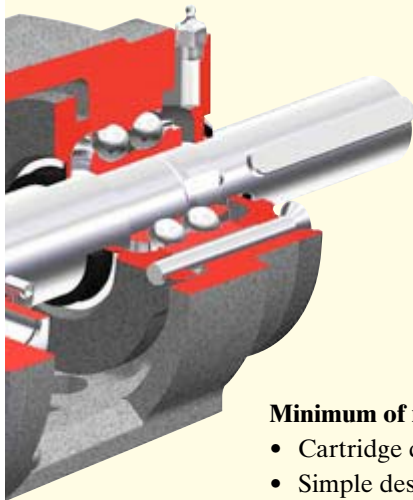

Minimum of maintenance

- Cartridge design
- Simple design

Maximised lifetime

- Compact rotor
- Strong shafts
- Maximized bearing design
- Possibility for selection of hardmetal bearings
- On seals thanks to seal relief channel

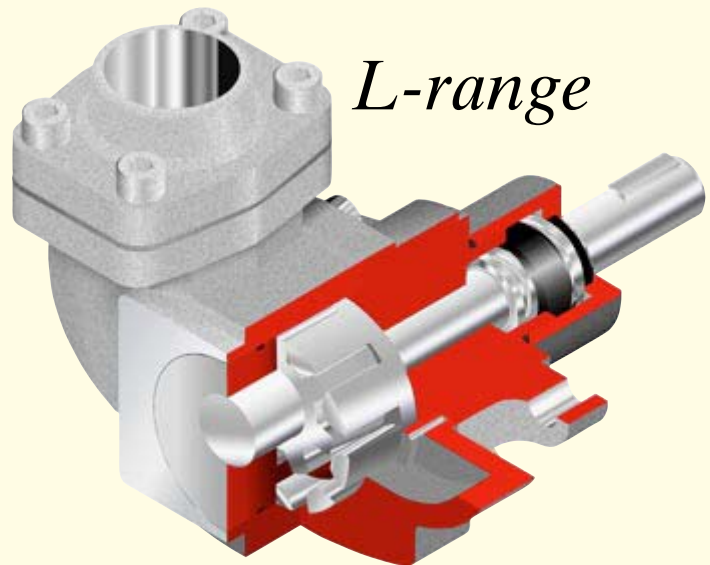
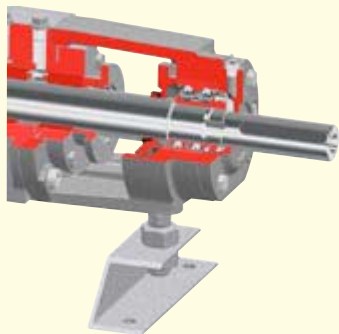

Less down time

- Pumps and motors flanged to pedestals
 - correct alignment between pump and drive shaft
- Compact units easy to assemble

Prolonged seal life

- Pressure relief channel from the seal area back to the suction side

Large vertical ports

- Improved priming capability
- Reduced risk of cavitation

Options

Shaft seal options

Shaft seal options include packed gland, single and double mechanical seals (to EN 12756), lip seals and cartridge seals.

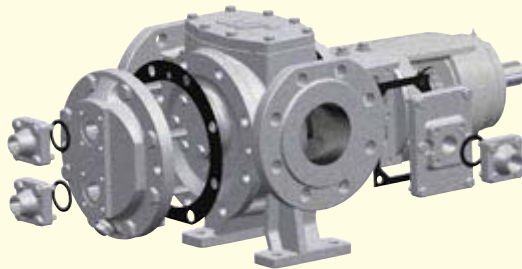
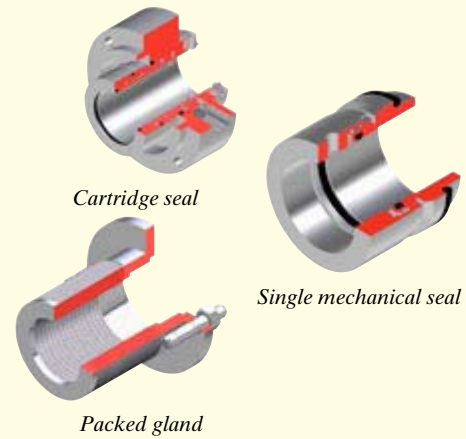

Jackets for pump cover and around the shaft seal

Jacket options

Heating and cooling jackets guarantee the performance of the pump in a start-up or a shut-down procedure. They also provide the pump with the best condition for the seals during operation. Different options : thermal oil, steam or electrical heating.



Single safety relief valve

Safety relief valve options

Built-on safety relief valves protect the pump, as well as other equipment in the system, from overpressure.

When the pump is used bidirectionally, a double safety relief valve is provided.



Double safety relief valve

Operating principle

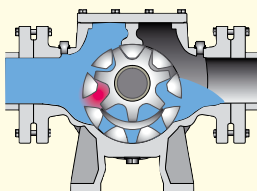

As the rotor and idler unmesh, an underpressure is created and the liquid enters the newly created cavities.

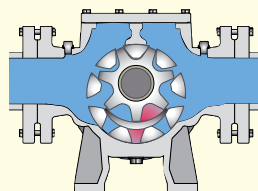

Liquid is transported in sealed pockets to the discharge side.

The walls of the pump casing and the crescent create a seal, that separates suction from discharge side.

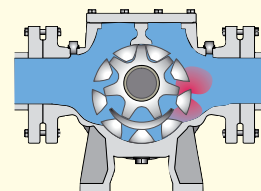

The rotor and idler mesh and liquid is pushed into the discharge line.

Technical data

	TG L	TG G			TG H
		TG GS	TG GP	TG GM	
Casing	Cast Iron	Cast Iron			Stainless Steel Cast Steel Ductile Iron
Idler & rotor	Steel	Iron Stainless Steel			Nodular Iron Stainless Steel
Max Capacity (m ³ /h)	9.5	250	250	125	125
Max differential pressure (bar)	20	10	16		20
Max temperature (°C)	250	200	300		300
Max viscosity (m.Pas)	80 000	5 000	80 000		80 000

General performance

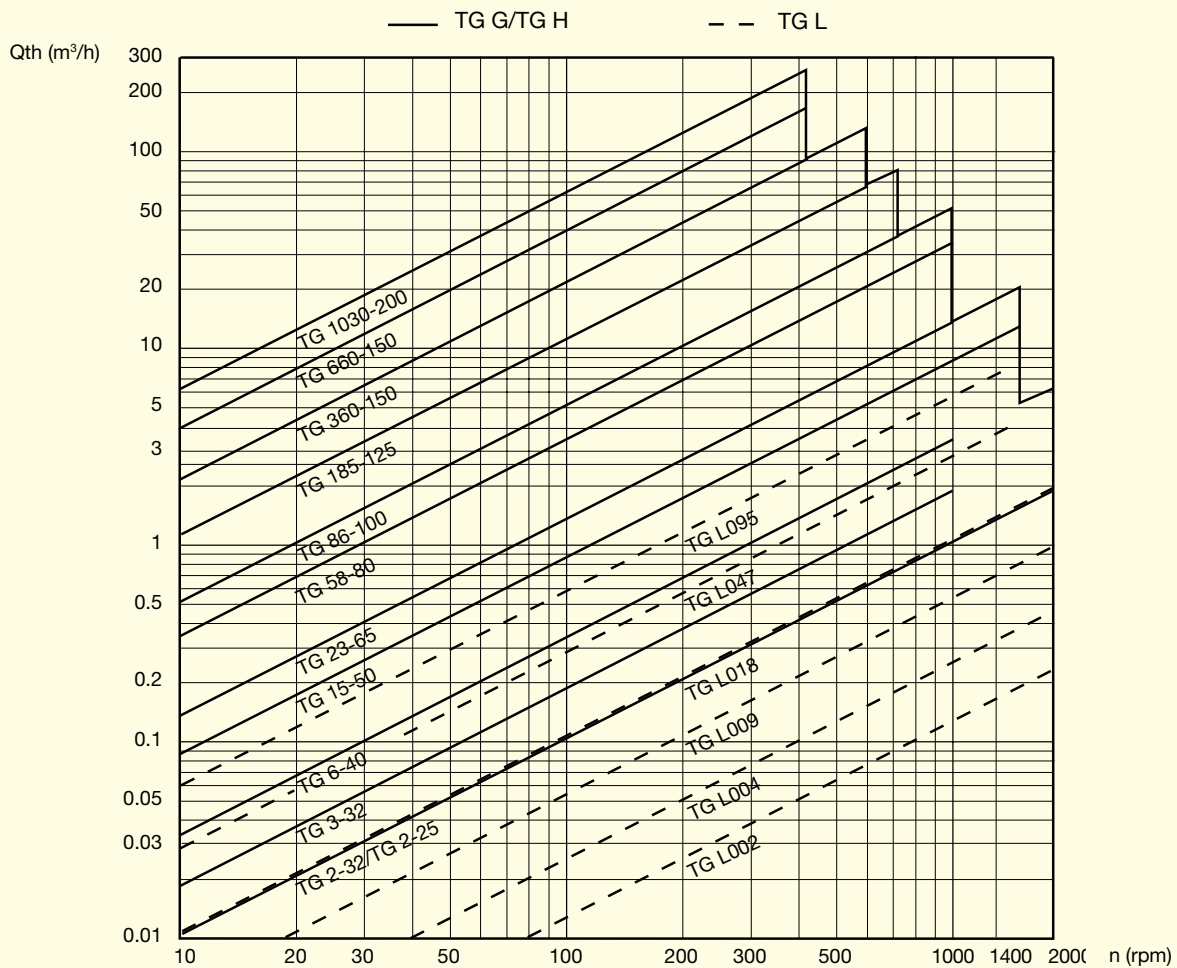



Johnson Pump Group

Parent Company

SWEDEN

Johnson Pump AB
Tel. +46 (0)19 21 83 00
Fax +46 (0)19 27 23 30

National Sales Organisations

AUSTRALIA

Johnson Pump (Australia) Pty. Ltd.
Tel. +61 (0)7 3899 9933
Fax +61 (0)7 3899 8574

BELGIUM

Johnson Pump N.V./S.A.
Belgium:
Tel. +32 (0)2 422 15 50
Fax +32 (0)2 422 15 59

DENMARK

Johnson Pumper A/S
Tel. +45 43 52 24 00
Fax +45 43 52 15 77

FINLAND

Johnson Pump Oy
Tel. +358 (0)9 348 3800
Fax +358 (0)9 348 38495

FRANCE

Johnson Pompes
Tel. +33 (0)1 39 20 50 00
Fax +33 (0)1 39 56 54 22

GERMANY

Johnson Pumpen GmbH
Tel. +49 (0)5731 480 80
Fax +49 (0)5731 414 00

ITALY

Johnson Pump Italiana S.r.l.
Tel. +39 039 604 14 63
Fax +39 039 604 90 97

NETHERLANDS

Johnson Pump B.V.
Tel. +31 (0)592 37 67 67
Fax +31 (0)592 37 67 06

Johnson Pump Horticulture
Tel. +31 (0)174 51 84 10
Fax +31 (0)174 51 84 44

NORWAY

Johnson Pump A/S
Tel. +47 22 74 08 40
Fax +47 22 22 70 30

SPAIN

Johnson Pump España, S.L.
Tel. +34 972 58 08 01
Fax +34 972 58 08 03
Sales Office:
Madrid: Tel. +34 91 888 79 22

SWEDEN

Johnson Pump Svenska
Tel. +46 (0)19 21 83 70
Fax +46 (0)19 27 23 18

SWITZERLAND

Johnson Pumpen AG
Tel. +41 (0)43 477 71 22
Fax +41 (0)43 477 71 20

UNITED KINGDOM

JP Pumps Ltd.
Tel. +44 (0)1293 55 34 95
Fax +44 (0)1293 52 46 35
Northern Regional Office:
Bradford: Tel. +44 (0)1274 74 22 47
Fax +44 (0)1274 74 22 28

Business Units

BELGIUM

Johnson Pump Brussels N.V.
Tel. +32 (0)53 60 27 15
Fax +32 (0)53 60 27 01

INDIA

Johnson Pump (India) Ltd.
Tel. +91 (0)79 2287 03 11
Fax +91 (0)79 2287 25 22

NETHERLANDS

Johnson Pump Water B.V.
Tel. +31 (0)592 37 67 67
Fax +31 (0)592 37 67 60

SWEDEN

Johnson Pump AB
Tel. +46 (0)19 21 83 00
Fax +46 (0)19 27 23 72

USA

Johnson Pumps of America, Inc.
Tel. +1 847 671 7867
Fax +1 847 671 7909



In addition to our own companies we are represented by independent distributors in over 50 countries worldwide.

www.johnson-pump.com



JP Pumps Ltd.

Head office: Meadow Brook Industrial Centre, Maxwell Way, Crawley, West Sussex RH10 9SA. Tel. 01293-553495. Fax 01293-524635

Northern Regional Office: Fieldhead Business Centre, Listerhills, Bradford BD7 1LG. Tel. 01274-742247. Fax 01274-742228

E-mail: mailbox.uk@johnson-pump.com Web: www.johnson-pump.com/UK