

NEXTECH-1™

**NEXTECH-1™ Low Pressure Trunnion
ANSI 300 – 900
Temperatures up to 1500° F
2" - 12"**

The Valvtechnologies low pressure, trunnion-style, metal-seated ball valves incorporate many of the features of the traditional "fixed-floating" design into a lower-torque, bi-directional valve. The Nextech-1 features a readily adjustable stem sealing design with a four-stud, live-loaded, industrial-grade packing gland assembly and offers diamond mate-lapped Tungsten or Chromium Carbide RAM® coating on sealing surfaces. The split-body design allows for ease of maintenance and the Grafoil®/Inconel seals and packing allow for high temperature operation. The Nextech-1 is available in sizes 2" – 12" and in a variety of end connections to meet customer's specifications.

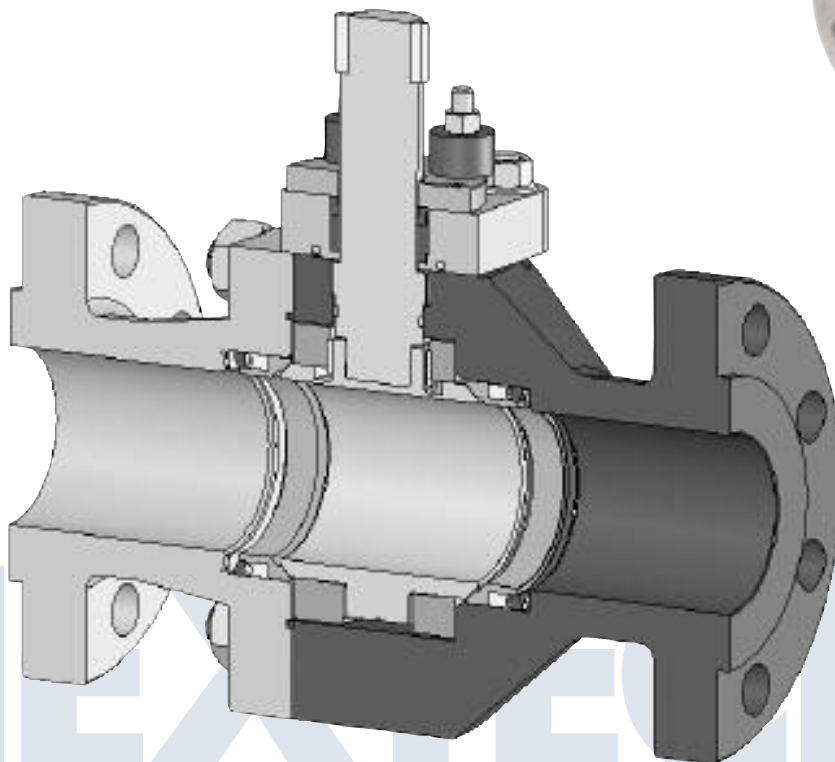

NEXTECH-2™

NEXTECH-2™ High Pressure Trunnion
API 5000, 10000, 15000 ANSI 900 - 4500
Temperatures up to 1500°F
2" - 36"

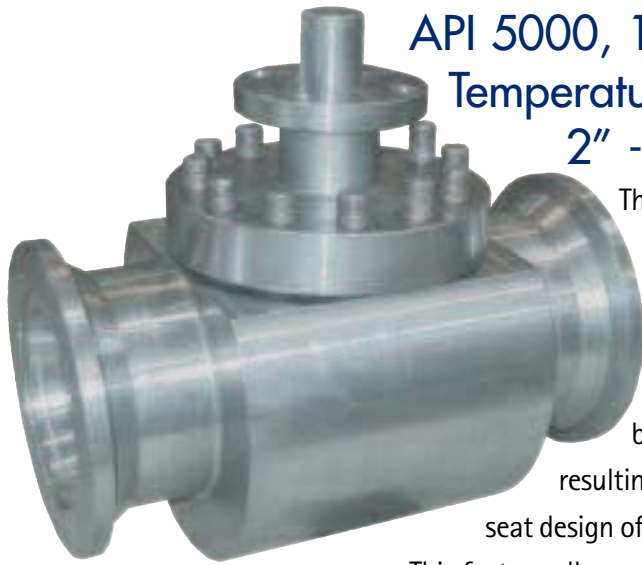

The Nextech-2™, high pressure trunnion-mounted valve offers a variety of unique design solutions that are suitable for both the API specifications and ANSI codes.

The torque for the Nextech-2 is much lower than a floating ball valve, this allows for smaller actuators to be used; resulting in major cost and space savings. Additionally, the dual seat design of the Nextech-2 provides a positive bi-directional shut-off.

This feature allows an operator to check the center tap for leakage and other particulates while the valve is in the fully open or closed position. Another exclusive option of the Nextech-2 is the in-line repairable, top-entry design. If disassembly is required while the valve is in-line, the top entry Nextech-2 design is the solution. The top-entry design allows an operator to easily remove the ball and seats through the bonnet. The Nextech-2 zero leakage, high pressure trunnion valve is the successful answer for your process application.

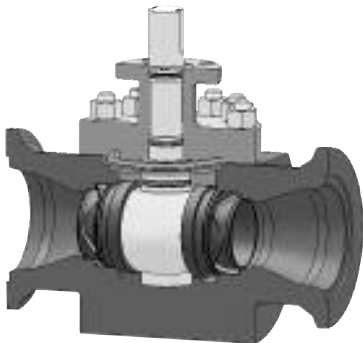

NEXTECH-2

SUBSEA

Subsea Trunnion Valve API 5000, 10000, 15000 ANSI 900 - 4500

Valvetechnologies trunnion valves for subsea applications are designed for MOV coupling and a complete panel option is available. The trunnion is suitable for depths of 12,000 feet in subsea applications, available in sizes 2" - 36", API pressures 5000, 10000, 15000 and in a variety of material options, including metal and PEEK™ seats.

The Nextech-2 trunnion design is an effective solution for subsea applications. The (one-piece body design) handles solids and requires minimum maintenance. Additionally, an option for Hyperbaric testing by an independent lab offering a 12,000 feet certificate is available.

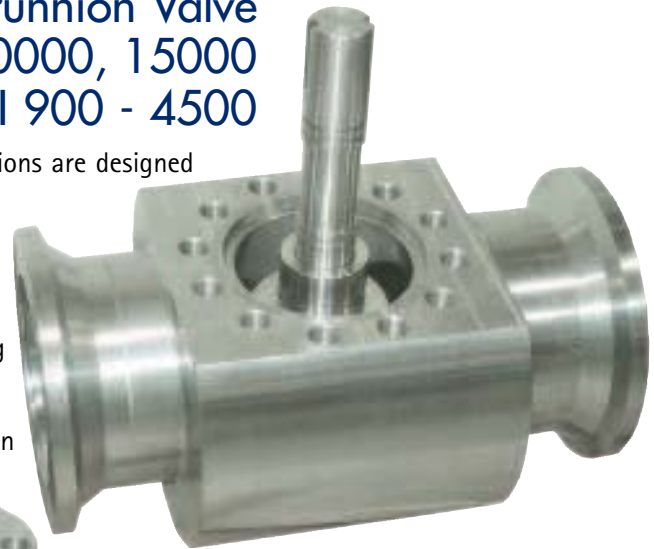

The Nextech-2 one piece body design requires minimum maintenance and is zero leakage.

Applications:

- Flow lines
 - Emergency Shut Downs
 - Subsea Isolation
-



The Nextech-2 has been independently certified to 12,000 feet below sea level

HIPPS

Valvtechnologies has partnered with Subsea and Offshore, Inc. in presenting SIL III-rated Integrity HIPPS Systems.

High Integrity Pressure Protection Systems (HIPPS) are used to reduce the risk of damaging upstream piping in situations where operating pressure exceed design pressures.

Unfortunately, mechanical relief systems cannot be used in high pressures and flow rates are present. Environmental complaints and strict plant safety requirements are greater than normal. The use of a logic solver system with instrumentation protection is the preferred solution

Special materials, stringent testing and over sized actuation are key elements to ensure the valves will isolate in an emergency. Valvtechnologies zero leakage metal seated ball valves are suitable for these requirements and the system exceeds SIL 1 requirements.

The system includes:

- *state-of-the-art software package with a logic solver*
 - *instrumentation*
 - *chemical injection system*
 - *choke control*
 - *Valvtechnologies zero leakage ball valves*
-

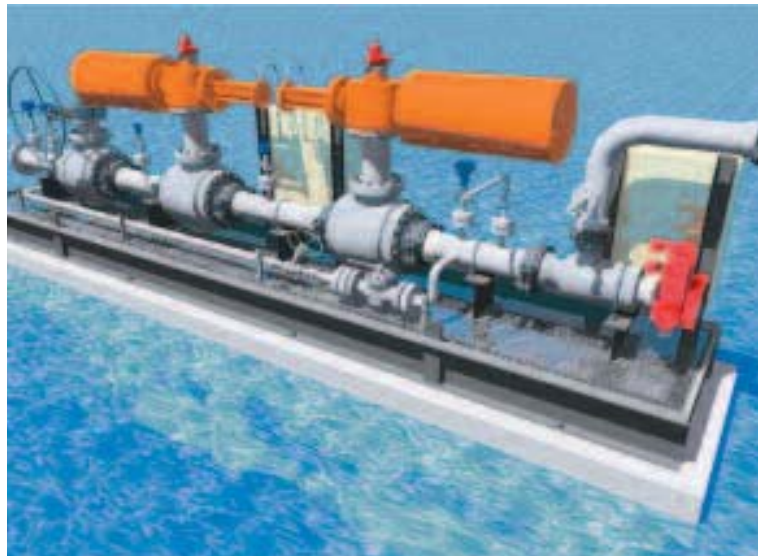

V1-1

Forged, High Pressure Valves ANSI 900 - 4500 1/4" - 4"

The flagship of the Valvtechnologies' product line, the V1-1, is the valve by which all other metal-seated ball valves are measured. The V1-1 design includes integral seats, RAM™ hard coatings, blowout proof stem and live-loaded packing. Primarily used in high-energy applications in the Power Industry, the V1-1 is available in sizes from 1/4" to 4", and ANSI pressure classes 900 to 4500, including interpolated and special ratings. V1-1 valves are manufactured in a variety of forged materials and end connections to meet our customers' specifications.

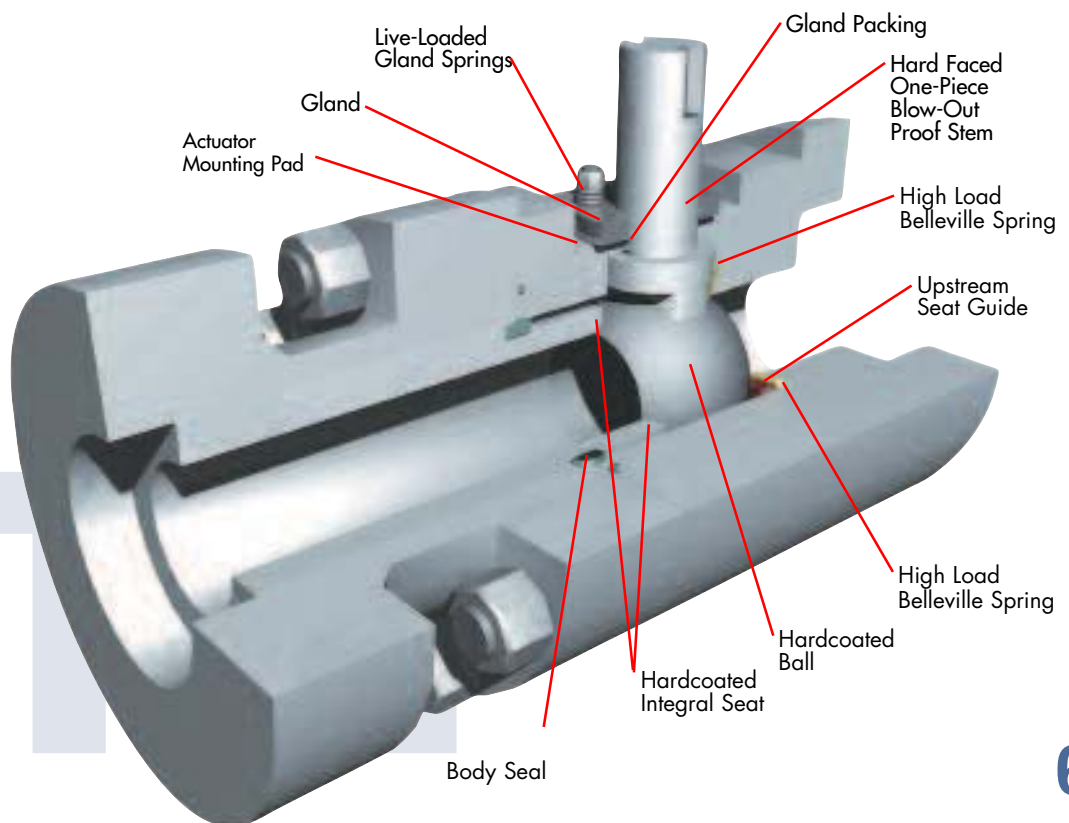

V1-2



High Pressure, Flanged Valves ANSI 150-600 1/2" - 36"

The V1-2 valve applies our core design concepts to industrial processes where lower pressure classes are more common. The V1-2 is available in pressure classes 150 to 600, sizes 1/2" to 36", and in virtually any cast or forged material. The valve can be custom designed to include special end connections, purge ports, cavity fillers, cryogenic stem extensions, fugitive emission bonnets, abrasion resistant linings and many other process-specific options. Furthermore, the standard V1-2 design is fire safe to the API 607 Rev. 4 fire test standard.

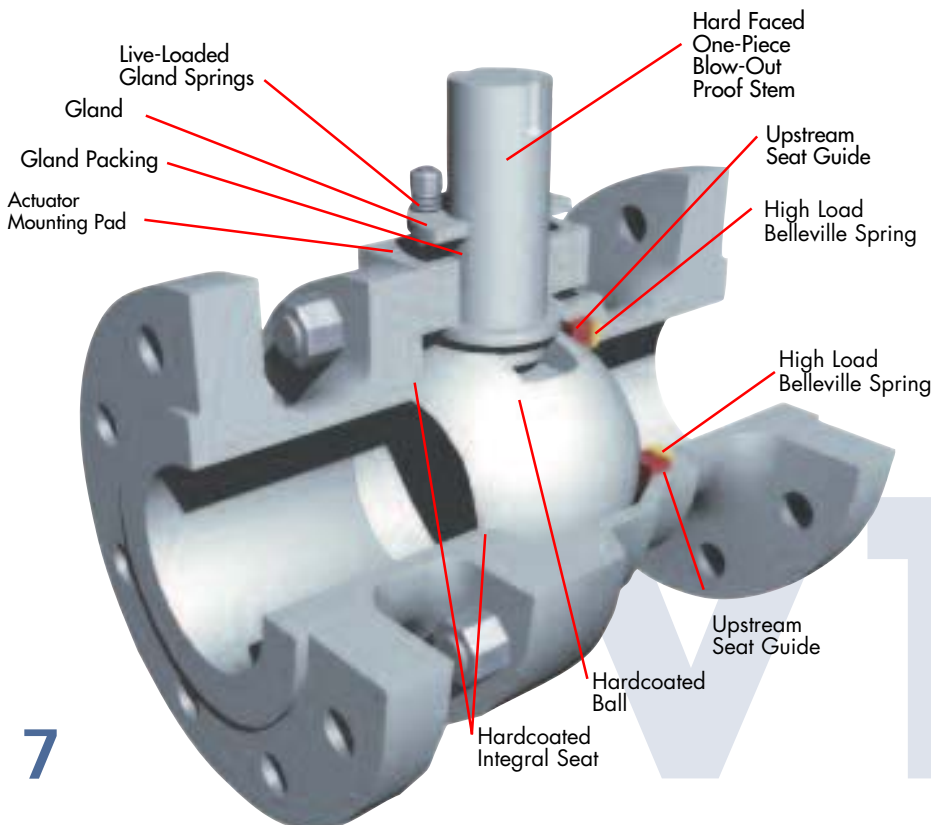
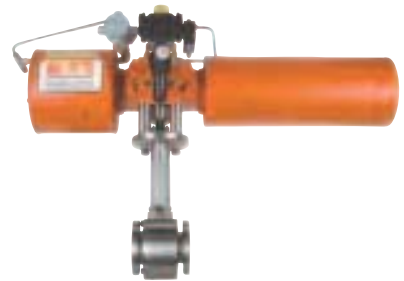

V1-3/V1-4

Investment Cast Valve ANSI 150-600 1/2" to 2"

The V1-3 is an investment cast valve that incorporates the Valvtechnologies core design into a smaller package. Primarily used in low-pressure drain applications, the V1-3 is available in ANSI pressure class 150 to 600, in sizes 1/2" to 2" and in both full and reduced-port configurations. End connections are typically butt weld or socket weld, or can be adapted to our customers' specifications. As with all of the Valvtechnologies product line, the V1-3 features RAM® hardcoatings, a blow-out proof stem, live-loaded packing and absolute zero leakage.



High Pressure Large Bore Valves ANSI 900-4500 4" to 36"

The V1-4 category extends our core design concepts to larger diameter and higher pressure applications. The V1-4 is available in ANSI pressure classes 900 to 4500, in sizes 4" to 36" and in virtually any material with pressure containing parts made from forgings. Standard end connections are butt weld and flanged or valves can be custom designed to include special end connections; as well as purge ports, cavity fillers, fugitive emission bonnets, abrasion resistant linings and many other process-specific options.



PRODUCTS

PRESSURE RELIEF



Valvtechnologies Electronic Relief Valves provide precise pressure relief and control.

The Valvtechnologies Electronic Relief Valve (ERV) provides accurate pressure relief and assures repeatable, zero-leakage shutoff. The ERV includes a piezo-resistive transducer and electronic controller that allow process operation to .1% of set pressure and the system is accurate to .01 psig. The ERV's performance exceeds that of conventional spring-loaded or pilot operated safety valves and also of more primitive, buckling-pin type valves. The integral, metal-seated design is virtually maintenance-free and is backed by Valvtechnologies' Four Year Zero Leakage Guarantee. The ERV is available in a variety of materials, sizes, pressure classes and end-connections.



Electronic Relief Valve

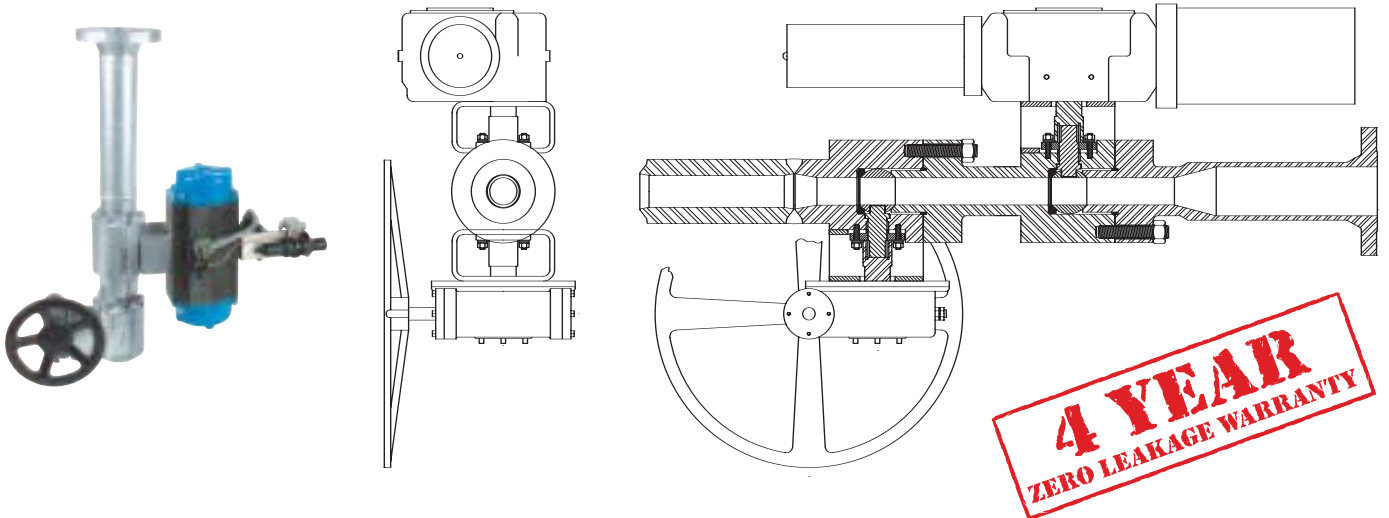

XACTROL™



Severe Service Control Valve ANSI 150-4500 1/2" - 36"

The Xactrol™ product group unites Valvtechnologies' zero-leakage technology with special designs that allow rotary modulating control. From Mark I design that features a characterized upstream seat, to the Mark III's precision engineered stacked discs, the Xactrol™ allows the customer to combine precise flow control with tight shutoff. The Xactrol™ is typically used in applications where minimum flow and relatively high differential pressures are required. It is available in sizes from 1/2" to 36" and in pressure classes ANSI 150 to 4500.

COMMON CONFIGURATIONS



Xactrol™ Tandem Arrangement with Automated Isolation Valves

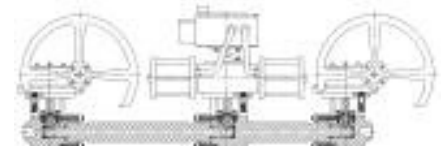

Xactrol™ Tandem Arrangement with Manual Isolation Valves

BILL OF MATERIAL

ITEM	DESCRIPTION	MATERIAL	QTY.
1	BALL	410 S.S./RAM31	1*
2	UPSTREAM SEAT ASSY.	A182-F22/17-4	1*
3	BELLVILLE SPRING	INCONEL	1*
4	STEM	A638 GR. 660	1
5	GLAND	A182-F22/H.F.	1
6	GLAND LOAD SPRING	304 S.S.	24
7	GLAND NUT	A194Gr. B8M	4
8	GLAND STUD	A194Gr. B8M	4
9	END CAP	A182-F22/RAM31	1*
10	BODY	A182-F22	1
11	BODY GASKET	17-4 PH/GRAFOIL	3*
12	GLAND PACKING	GRAFOIL/316 S.S.	3*
13	KEY	STEEL	2
14	-	-	-
15	DRIVE SLEEVE	4130	1
16	POSITIONER	-	1
17	BODY STUD	A193 Gr. B8M	6
18	BODY NUT	A193 Gr. B8M	6
19	YOKE CAP SCREWS	A193 Gr. B7	4
20	YOKE POST	STEEL	4
21	YOKE PLATE	STEEL	1
22	PNEUMATIC ACTUATOR		1

* Recommended Spare Parts

ISOTECH™

Valvtechnologies ISOTECH™ ESD System allows for *in situ* valve testing and repair.

The Valvtechnologies patented ISOTECH™ ESD System allows the end-user to detect seat damage while the valve is in the OPEN position. Seat damage is detected by monitoring pressure in the leak detection port. A pressure increase indicates that zero-leakage isolation might not be possible if the valve needs to close. This revolutionary method of on-stream analysis assures a measure of reliability unknown in the Oil & Gas industry. Furthermore, the ISOTECH™ ESD Valve can be automatically repaired *in situ* at the very instant in which it is required to close. The repair is accomplished by injecting a high-viscosity, fluoropolymer compound into the sealant injection groove. The compound fills the seat groove and seals the damaged area against the ball. In this system, as in all of our valves, we guarantee zero-leakage isolation. The ISOTECH™ ESD system can be configured to include components which are TÜV approved for SIL 1,2 and 3 applications per IEC61508.

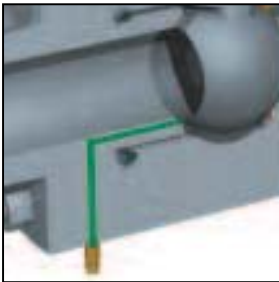

No Seat Damage

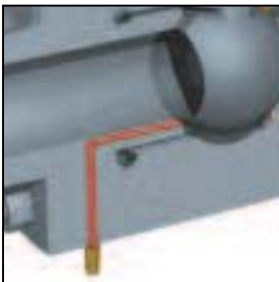

Seat Damage Detected

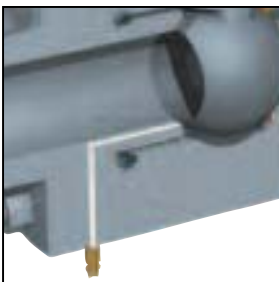

in situ Repair

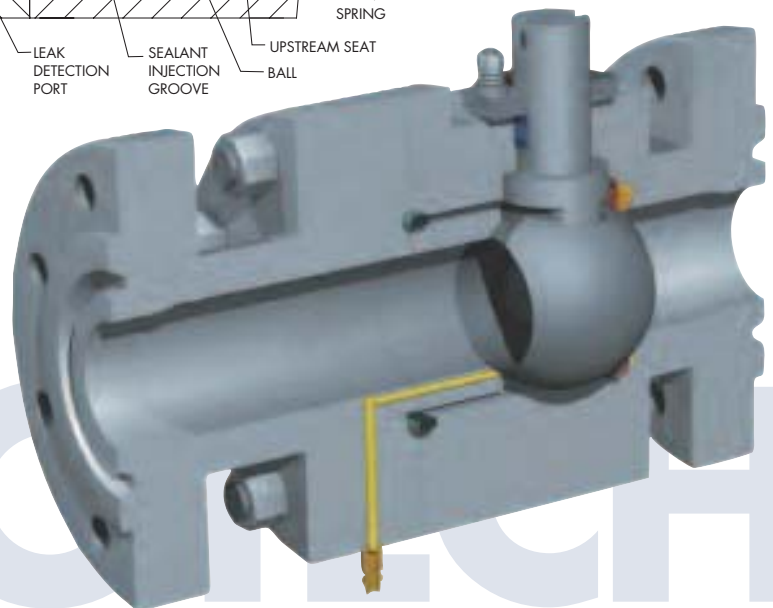
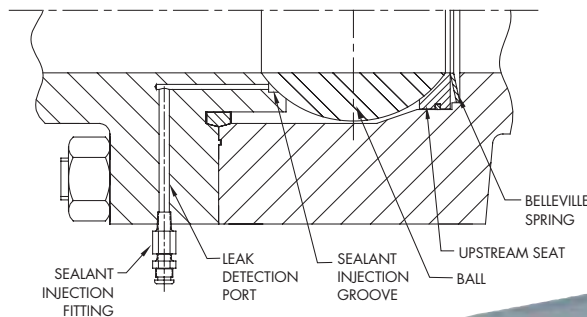

ISOTECH™

GAS PROCESSING

Valvtechnologies designs valves specifically for the demands of gas processing applications.

Valvtechnologies provides zero-leakage isolation and control valves for the upstream and midstream gas processing industry. Processes such as gas treating, NGL recovery, acid gas injection and sulfur recovery also require emission-free performance in critical valve applications. The Valvtechnologies live-loaded stem seal passes the most stringent fugitive emissions requirements with detectable leakage of less than 1×10^{-3} ATM mL/sec in a helium leak test. For the most severe gas processing applications with high H₂S content, Valvtechnologies is certified to build valves to API 6A PSL 3&4.



TYPICAL SPECIFICATION FOR CRA VALVES	
DESIGN	API 6D, API 6A PSL3, NACE MR0175
BALL	INCONEL 625/RAM™31 CHROME CARBIDE
UPSTREAM SEAT	INCONEL 625
BELLEVILLE SPRING	INCONEL 718
END CAP/INTEGRAL SEAT	A350 LF2/INCONEL 625 CLAD/ RAM™31 CHROME CARBIDE
BODY	A350 LF2/INCONEL 625 (MIN. .125" OVERLAY)
BODY GASKET	INCONEL 718
GLAND PACKING	LIVE LOADED INCONEL/GRAFOIL
BODY STUD	A193 Gr. B7M/XYLAN COATED
BODY NUT	A194 Gr. 2HM/XYLAN COATED
NDE	Bond Strength--Immersion Ultrasonic Testing Clad Thickness--UT or Eddy Current Testing Wet Magnetic Particle Surface Testing
HYDROSTATIC TESTING	API 598--Hold Period of 15 Minutes
SEAT TESTING	API 6D Appendix C Testing Medium is Nitrogen with Valve Assembly Fully submerged in Water 15 Minute Full Working Pressure Test 15 Minute Low Pressure Test No Leakage Permitted during 30 Min. Hold Period Zero Bubbles shall be Observed in the Water

Gas Processing Applications

- Mole Sieve Switch Valves
- Joule-Thomson Valves
- Turbo Expander Bypass
- CRA Valves for High H₂S
- Acid Gas Injection Valves
- Vent-to-Flare Valves
- Pump Isolation Valves
- Amine Contactor Level Control
- Hydrogen PSA Valves



Gas Processing Diagram

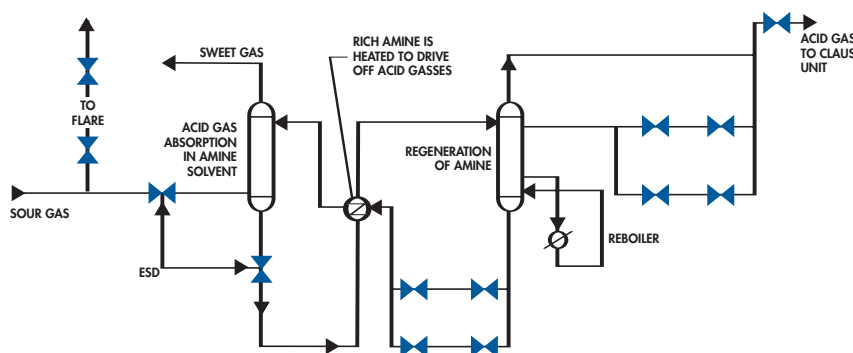

H₂S
12

STEAM INJECTION



RAM™ Coatings Resist Abrasion and Corrosion.

Valvtechnologies metal-seated ball valves are well suited to the requirements of all types of well injection, including SAGD and acid gas injection. The RAM™ coatings assure repeatable, zero-leakage isolation regardless of debris and abrasive contaminants like sand and other particulates. The RAM™ coatings also provide corrosion protection if the injection medium contains high concentrations of chlorides. The Valvtechnologies Four Year Zero-Leakage Guarantee assures long term isolation valve performance.



**4 YEAR
ZERO LEAKAGE WARRANTY**



PIGGING

Valvtechnologies metal-seated design eliminates the problems caused by soft-seated valves.

Valvtechnologies metal-seated valves solve the serious problems that are caused by soft-seated valves in pig recovery, as well as in the dump and low-point drain lines. Our super-hard RAM™ coatings are impervious to the scale and debris that are carried with the pig into the receiving dock. The Valvtechnologies design provides repeatable zero-leakage isolation, allowing you to hold pressure in the system after multiple pigging cycles. If the installation is in a cold-weather region, we can use cavity fillers to prevent damage caused by freezing condensate.

Pigging Diagram

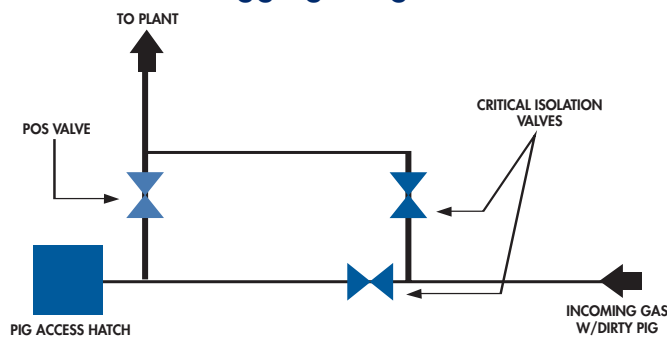

API 6D Full Port Valve

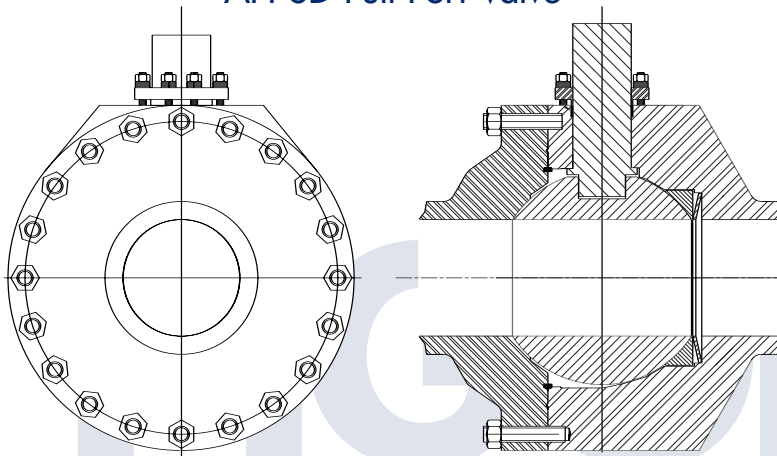

STEAM CHOKE

Steam Choke Valves

The Valvtechnologies steam choke is designed for the harsh conditions associated with steam injection. The rugged, maintenance-free steam choke features a self-adjusting, double live-loaded design.

A The stem/fork packing is isolated from the bonnet seal arrangement and is live-loaded. Belleville springs on the packing gland bolts self-adjust to maintain constant packing load regardless of thermal cycling. This design reduces the potential for packing leaks. Valvtechnologies offers a **four year zero emissions guarantee** for steam chokes. *



2" ANSI 1500 Steam Choke



Steam Cycle Testing

B Belleville springs accommodate for thermal expansion of the choke's internal components. During thermal cycling in startup or normal operation, the Belleville springs self-adjust to maintain an ideal contact load between the control discs. This self-adjustment eliminates the possibility of lockup--regardless of process temperature or pressure (within the material limits). The internal springs also provide a constant load to prevent external leakage through the bonnet packing.

C The control discs are designed to provide precise control so that production rates are controlled with a high degree of accuracy. The discs also provide long-term erosion resistance in high-velocity, saturated steam service. Various orifice shapes, sizes and configurations are available for a wide range of production rates and control requirements. The steam choke can easily be retrofitted with new discs if well conditions or production rates change over time.

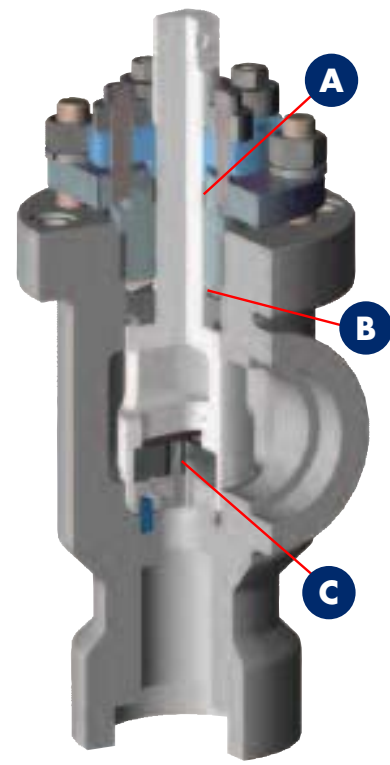

* Guarantee valid only if the Valvtechnologies, Inc. installation and operations procedures are followed.

CRYOGENIC

Valvetechnologies cryogenic valves undergo exhaustive process simulation testing.

The Valvetechnologies cryogenic design exceeds the test requirements of BS 6364. Valvetechnologies' cryogenic laboratory uses a proprietary vacuum test chamber as well as the more common immersion testing tanks. The vacuum chamber allows accurate process simulation that is not possible with the industry-standard test apparatus.



Cryogenic Testing

Cryogenic Valve Testing Unit

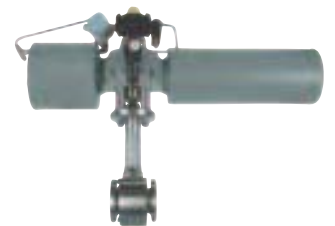
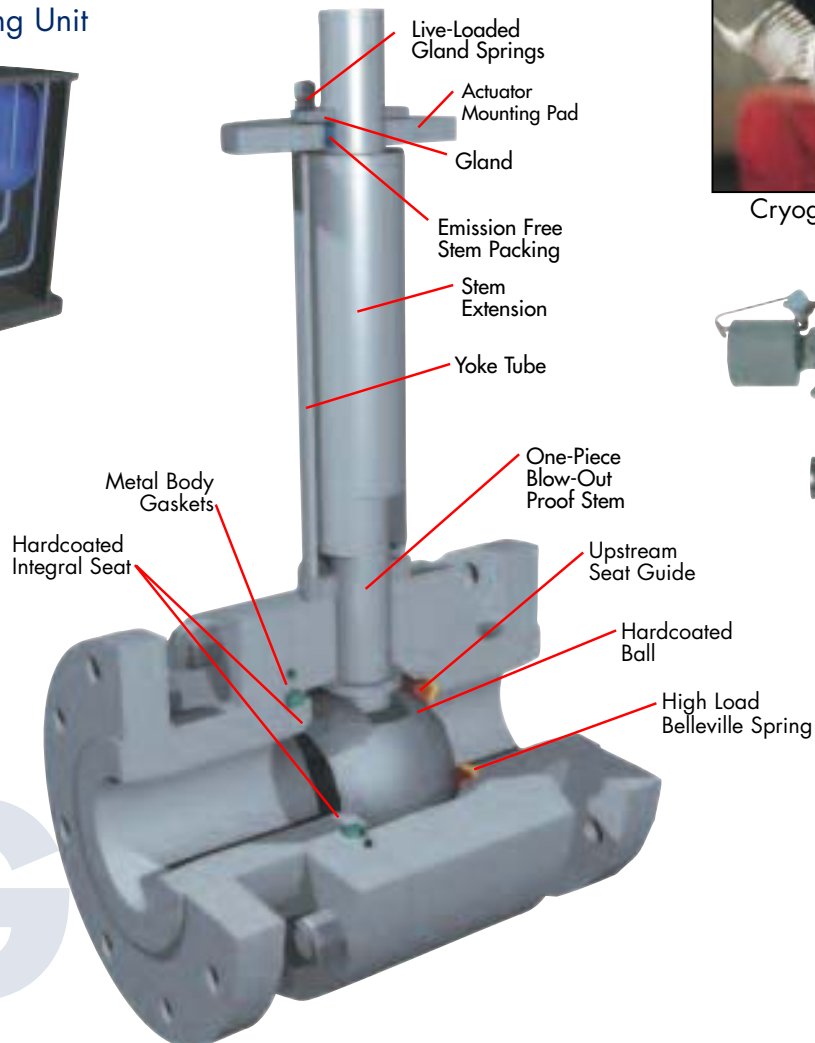

Cryogenic Applications

- Air Separation
- LNG Liquefaction
- LNG Regassification
- NGL Recovery
- CO₂ Separation
- Nitrogen Rejection
- Glycol Dehydration
- Ethylene Production

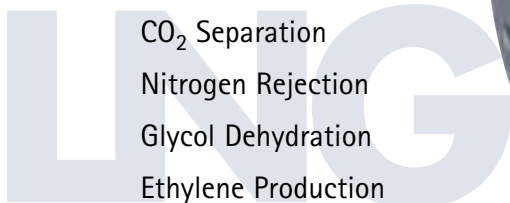

DOUBLE BLOCK & BLEED

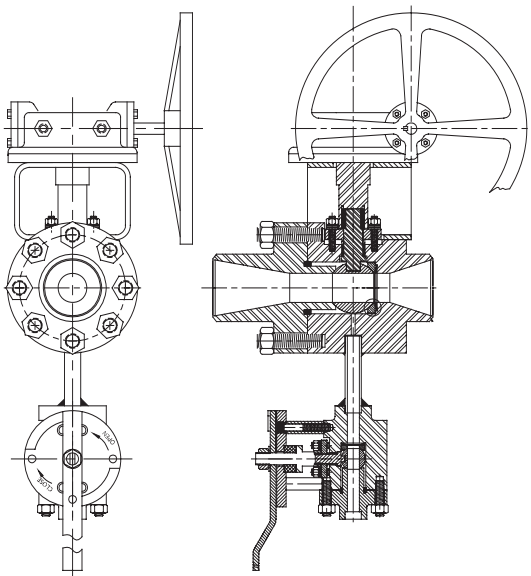

Valvtechnologies valves can be configured for Double Block and Bleed & Double Isolation service.

The Double Block & Bleed configuration features a bi-directional upstream seat system (see detail) as well as a bleed connection with a standard Valvtechnologies' isolation valve. Standard double block and bleed valves are available in a variety of materials and end connections. Double Block & Bleed service can also be applied to both the high pressure and low pressure Nextech trunnion valves as well as the cryogenic valve.

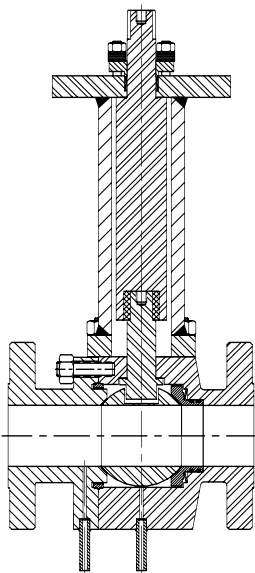

Valvtechnologies also offers a Double Isolation, Double Block & Bleed Valve configuration. The integral metal seat of the double isolation, double block & bleed configuration provides key safety solutions to isolating large equipment areas safely and effectively.



6" ANSI 300 Double Block & Bleed Valve

The design features a primary and secondary bleed port as well as a secondary back-up safety integral metal seat. The integral seat features RAM® 31 hardcoating that is hand-matte lapped to the ball providing metal to metal sealing and zero leakage. With a secondary bleed point in a double isolation valve, the maintenance technician has guaranteed security of two sealing seats between him and the process. The technician will also be able to confirm the seal is intact to ensure safety measures in maintaining the downstream equipment.

BLOCK & BLEED